

Etanorm SKD (Semi Knock-Down) with optimum efficiency

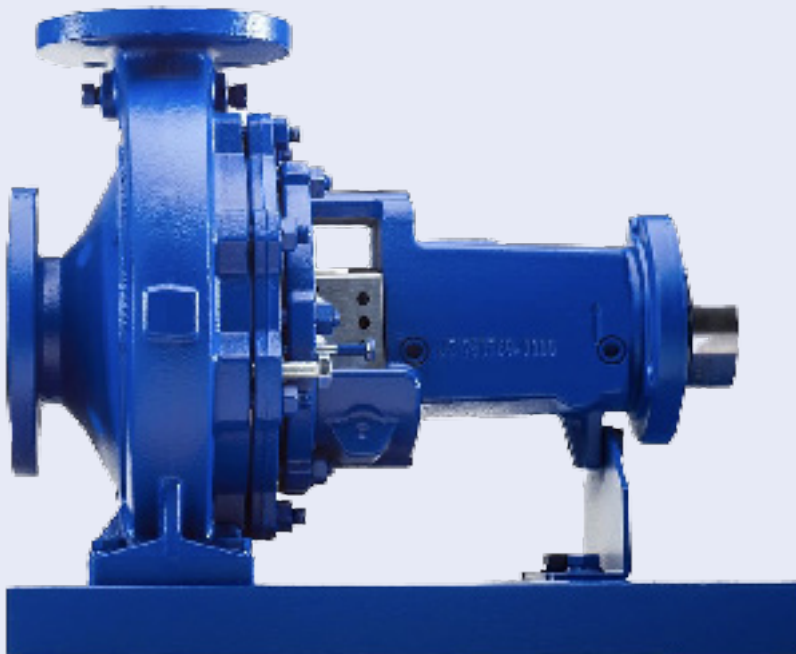

Applications:

- Clean water handling
- Water supply systems
- Cooling circuits
- Spare parts available for purchase

More information:
www.ksb.com/products

Etanorm SKD (Semi Knock-Down) with optimum efficiency

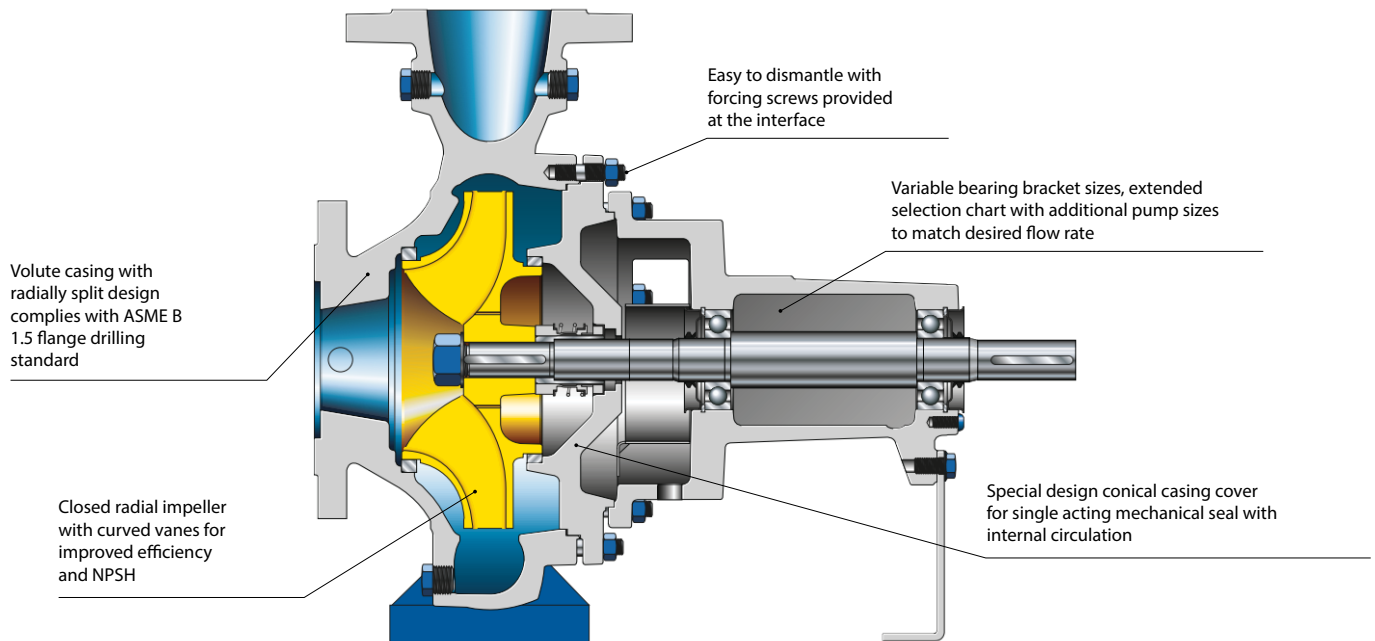

- 1 Quick Delivery
- 2 Adaptable production based on demand
- 3 Competitive Price
- 4 Easy Maintenance
- 5 Assembled locally (SKD)
- 6 Outstanding energy efficiency
- 7 Fastest spare parts service

Selection chart

Etanorm 200-150-200, n = 1450rpm

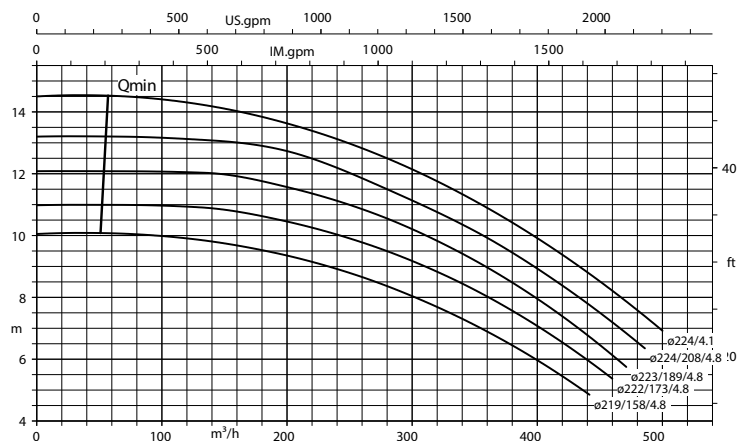

Technical data

Technical data	Etanorm SKD
Qmax	245,0 m ³ /h
Hmax	23,0 m
Pmax	30kW



KSB Indonesia
 Head Office, Cibitung. Telp: 021 89983570
 Jakarta. Telp: 021 80886509
 E-mail: ksbsales@ksb.com
 www.ksb.com/en-id