

KSB Tech at your Service

Technical Design Centre & IT Service Provider
for the KSB Group

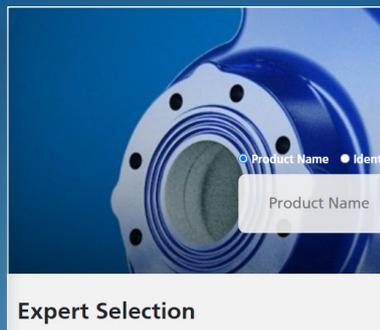

Innovation
Collaboration
Optimization
Networking

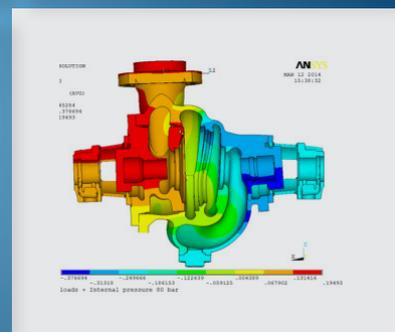

Our Vision

To have a diversified Customer base for Market Area, Regions, & establish as KSB Group's major reliable Global Center for Design & IT services. To venture into uncharted technologies like IIoT, Mechatronics, Digitalization, & become the most preferred partner of KSB Group companies in Engineering, IT Services, & in their Digital Transformation Journey.

Our Mission

We support KSB SE & Co. KGaA and group companies through professional solutions & services in **Engineering, Product Development, Information Technology** to secure strategic objective and operative success of KSB.

Our Introduction

KSB Tech Private Limited has been formed as a 100% subsidiary of KSB SE & Co. KGaA, Johann-Klein-Strasse 9, Frankenthal, Germany. KSB SE & Co. KGaA is more than 150 years old MNC; engaged in manufacturing and trading of a wide range of pumps, valves, its accessories and allied products. KSB products are used for handling and transportation of water, chemicals, sewage, etc. in various sectors such as agriculture, industry, energy, building, etc. KSB is a multinational company and has its presence in all the major countries of the world through its subsidiaries. KSB is a multinational company with global headcount over 15,000 employees.

KSB also has 170 service centres and over 3,000 service staff to provide inspection, maintenance and repair services worldwide.

To meet its global requirements of engineering inventions, designs, renovations, improvements and of developing and improving computer software and information technology programs useful for its business and activities, KSB Tech Private Limited was formed in 2005 in India.

Offload tasks to KSB Tech and enrich your pockets

- Derive more value for your money
- Reduce costs
- Overcome your budgetary constraints
- Avoid capacity sourcing outside KSB
- Get best quality service

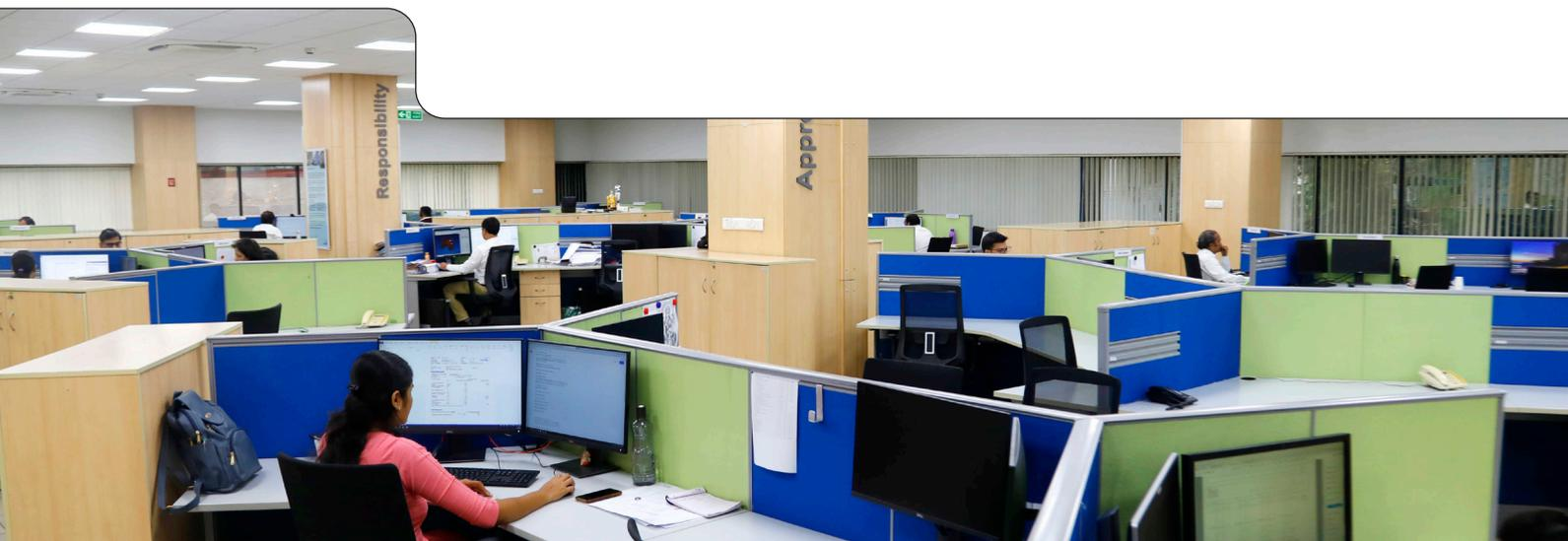

Product Development



SICCA / ECOLINE Gate



SICCA / ECOLINE Globe



SICCA / ECOLINE Check



UPA



WKTR

CHTRa



CHTR



RPHd

Construction / Design

Design support in Retrofitting



Pump Casing with Complex Geometry

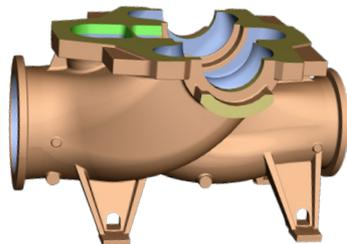

Hydraulic design of flow passages



Mechanical Design of Submersible Motors

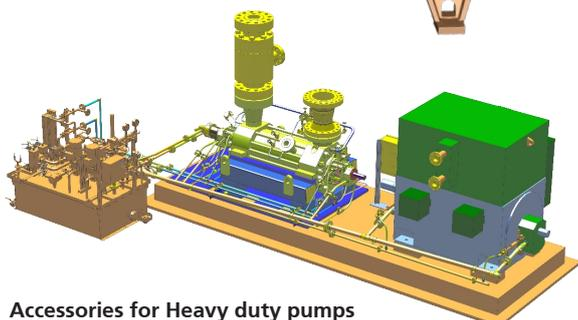

Accessories for Heavy duty pumps

Design Analysis

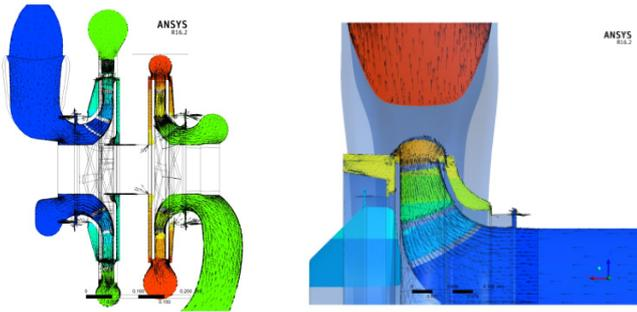

Flow analysis (CFD)

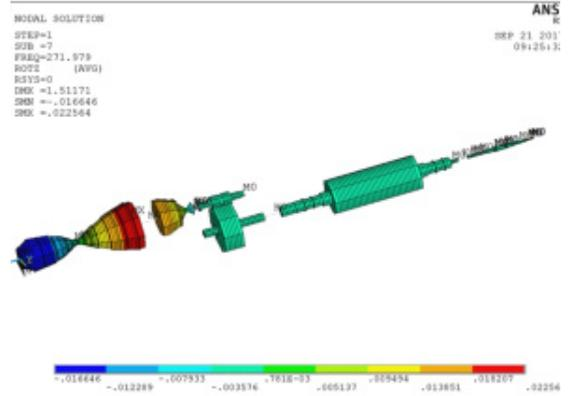

Rotor dynamic analysis

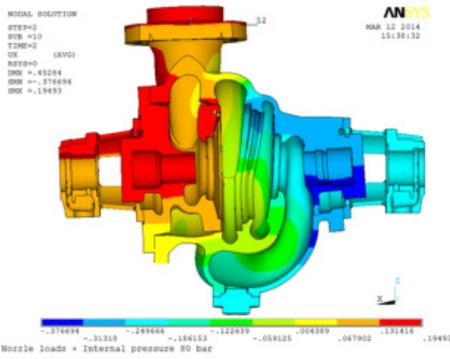

Stress and Stability analysis

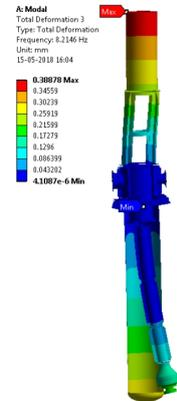
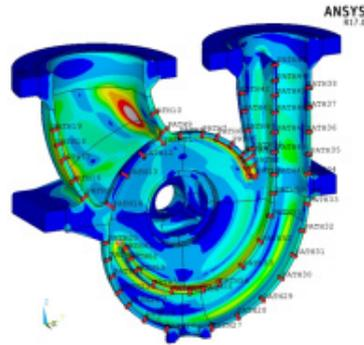

Dynamic analysis

CAD Services

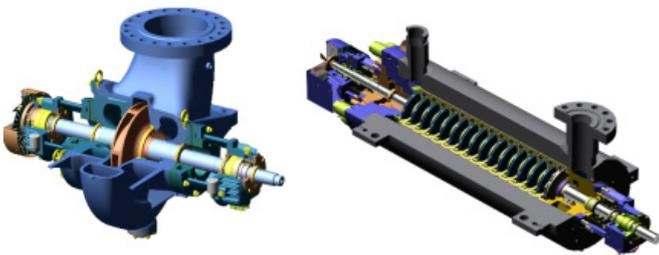

3D Modeling, Assembly & Drawings

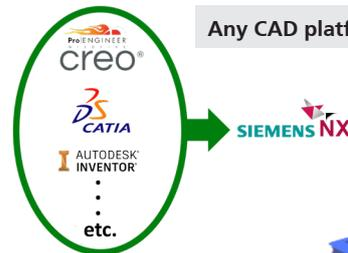

Any CAD platform » NX

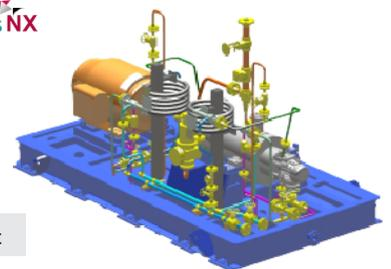

Routing Support

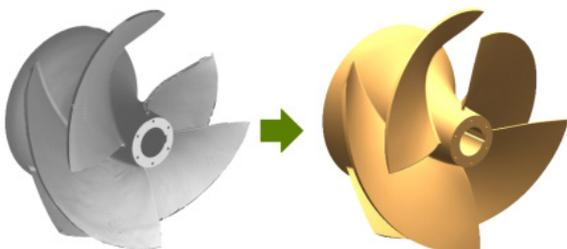

Reverse Engineering from point cloud

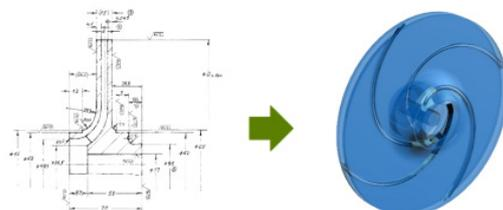

Paper Drawings to 3D Model

Design Tool Development

Diffuser Design Tool

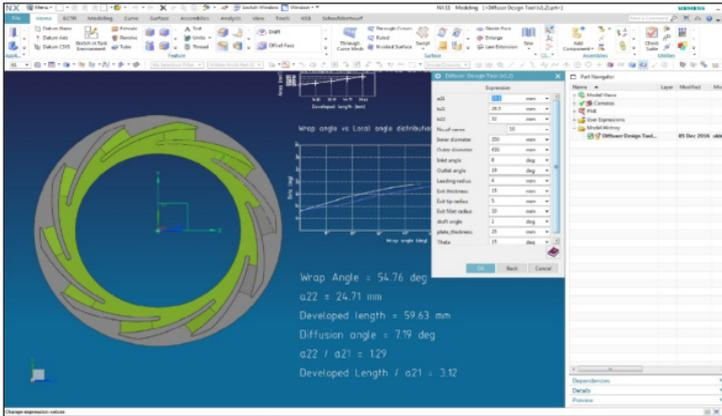

4 Quadrant Curve Program

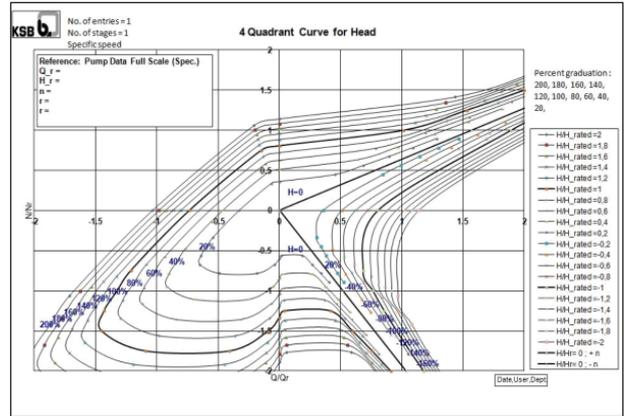

Program to Calculate Radial Thrust

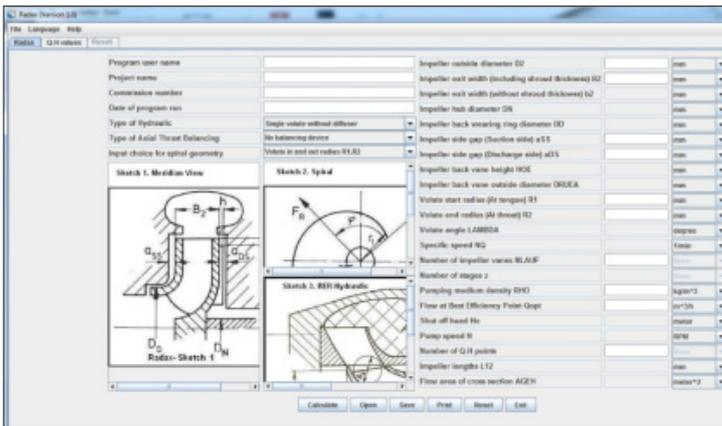

Automation of New Product Design

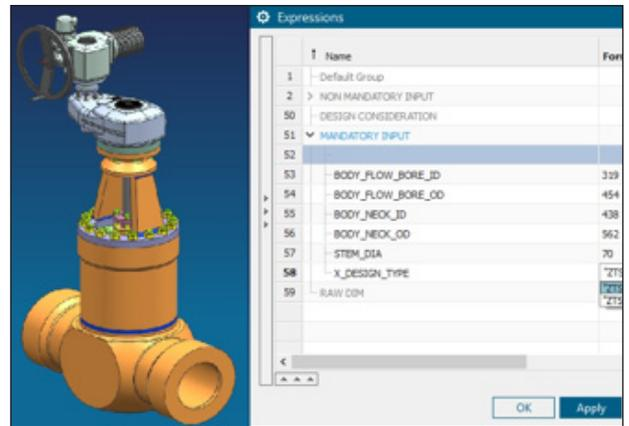

Technical Services

Technical documentation & translation

- Operating manuals
- Type Series booklets
- Characteristics Curve Booklets
- Supplementary Booklets
- Declaration of conformity
- Spare parts pricing
- Product Data Management
- MDR Ticketing
- Master Data Management
- Patent Research
- GA Drawings and layouts for Enquires / Sales Documentation
- Verification of Design Calculations
- Order documentation, Energy & petro\Chemicals projects
-many more

3D e-Catalogue of KSB Products

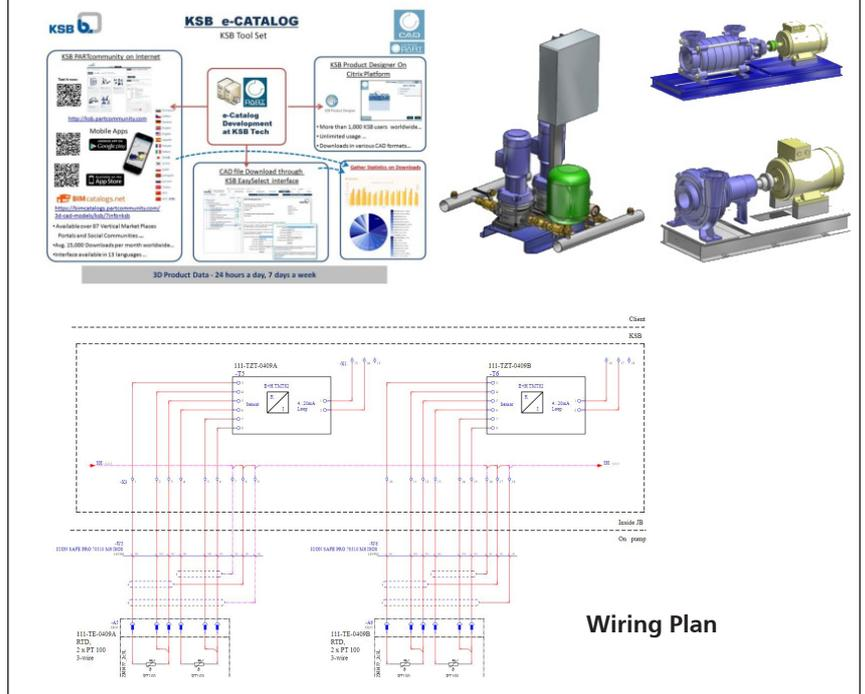

IT application system landscape

Our Central IT System and Application Landscape is hosted in Germany (On premises as well as in cloud). We use state-of-the-art technologies to support the ever increasing demand of the Business. Our central IT systems are used by more than 80 KSB locations/ countries worldwide covering close to 10000 users Locations and more than 8000 users, KSB worldwide.

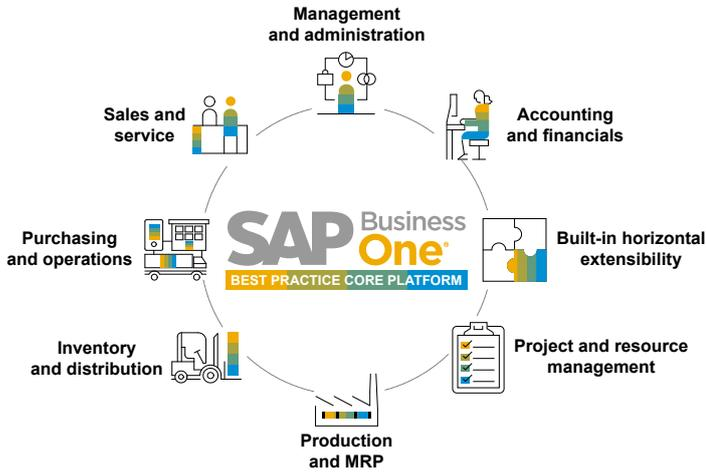

Being a part of Global IT Team, we provide support in all the following areas :

- Global Projects Roll-outs
- Production Support
- Continuous System improvement
- New implementation
- Version upgrade
- Training

Digital Unit (Software Engineering)

Keeping pace with Digital Transformation, our Digital unit (Software Engineering) is already playing an important role. Our Digital Unit is mainly working in three areas :

- eSales
- Industrial IoT
- Digital Factory

Our applications are hosted in Microsoft Azure and Amazon AWS Cloud.

Our software product solution includes :

- On-line Order processing
- Sales Configurator
- Applications using sensors data
- Preventive Maintenance alerts
- And many more...

We use state-of-the-art DevOps practices to Deploy and Manage software applications in cloud. We use Agile Processes for Software Product Development.

DevOps



Core Technology



Frontend



Robotics Process Automation & Collaboration

With a lot of focus towards Digital Transformation, KSB has started using RPA tools to automate Business Processes and Software Testing. As a first step towards Cloud Collaboration tools, we have started using MS Teams and Skype for Business extensively.

We have connected most of our KSB locations/ countries to our central IT systems using MPLS/SD-WAN

We provide Project Support in the area of Automation

- Robotic Process Automation (UiPath)
- Robotics Test Automation (Eggplant)
- IT Infrastructure Support (MS Teams, Skype for Business and IT Hardware and Network Support)

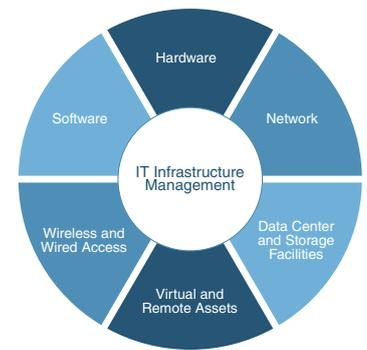

Sales Configurator

Product Selection Software Program

- EasySelect software development and implementation of new product using Camos.develope
- EasySelect Database administration and maintenance using MS SQL and PostGreSQL
- Automation testing by Eggplant tool and Camos Test centre
- Maintenance & upkeep of Pump selection softwares
- Implementation of new Product range using Spiax-5

Other Activities & Development :

- EasySevice tool development and maintenance
- Delivery time tool maintenance
- Deployment tool
- EasySelect Update tool
- Co-builder- BIM
- KSBuilding Consult
- KSB Helps
- KSBase Plug-in & SC support
- Product Implementation and maintainance

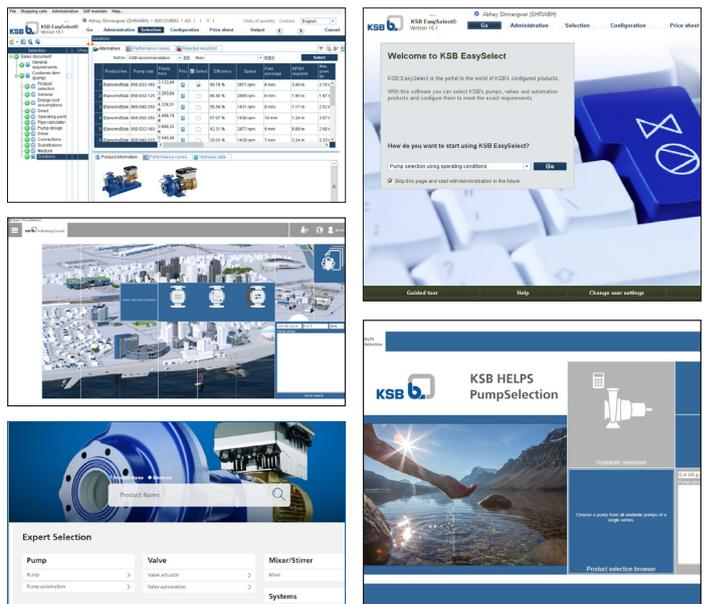

Overview of Key Skills & Capabilities

Capabilities

Product Development & Technical Product Responsibility

- Product care (including Customized design)
- Pump & Valve development acc. to international standards
- Feasibility study of new technical solution
- In-house development of tools for Calculations and Product Designs
- Value engineering
- Support to sales, service and works

Other technical services

- Implementation of products in Sales configurator (Product selection software)
- Database maintenance
- CFD Simulation
- FE Analysis
- Programming
- Master Data Management
- Drawings classification services / Variant Management
- Technical translation
- Technical Training (Domain Expertise in Products / IT)

CAD Services, Construction & design

- Mass production of 3D models and drawings
- Design related possibility study
- Construction of hydraulic wet surfaces
- Surface modeling from scanned 3D Data
- 3D e-Catalogue - Implementation in Cadenas
- Analysis of site complaints, retrofitting

IT services

- Software Development, Deployment & Maintenance
- Application & IT Infrastructure Services
- SAP Basis & ABAP programming
- SAP ERP (P14)
- C4C and C4S (Cloud for Customer & Cloud for Service) Projects and Support

- DevOps
- Business Intelligence and SAP Analytics Cloud
- Workday HCM
- Robotics Test and Process Automation

Skills

Construction & design

- Product (Pump & Valve) design expertise
- KSB design software (Siemens NX, PLM)
- Advanced surfacing skills in 3D modeling
- Programming of tools in 3D CAD platform NX
- Siemens NX-KF tools

Data management

- SAP knowledge - MDM services
- Database maintenance – Oracle, KM2002, Databases on KSB share point

Programming & Analysis

- Programming – CAMOS, Java, C#, C++ React JS, Angular JS, VBA, Excel, Cadenas
- CFD Simulation – ANSYS CFX
- FE Analysis – ANSYS, NX- Nastran
- NX- Nastran
- ABAP programming
- HCI (HANA Cloud Interface) & OData Services
- Microsoft .NET
- Robotics Process and Test Automation Development and implementation (Uipath, Eggplant)



DID YOU KNOW?

- KSB Tech is established in 2005.
- It is owned 100% by KSB SE & KGaA, Germany.
- It operates in a system environment that is identical to KSB SE & KGaA, Germany
- Has high security to protect your intellectual property



KSB Tech Pvt. Ltd.

Godrej Castlemaine, 2nd Floor, Bund Garden Road, Pune 411 001, Maharashtra (India).
Tel. 91 (020) 2600 7000 | Mail to : contactus_ksb-tech@ksb.com
Web : www.ksb.com/en-ksbtech

